

The Formal Characteristics of Auxiliary Verbs

PhD. (Professor Emeritus) Aziz Yousif Al-Muttalibi*
Aziz.yousif@muc.edu.iq

1. Abstract:

This paper tries to pin down the *formal characteristics* of auxiliaries. It introduces important grammarians who try to talk about this important grammatical issue.

The paper interestingly tries to show how these auxiliaries work in sentences, perceptively dividing them into **primary** and **modal** auxiliaries where in the first kind **BE** contributes to **aspect** and **voice** and **have** to **aspect** only. Disengagingly, it is shown that the **modal auxiliaries** contribute to **volition**, **probability** and **obligation**. **Modal Auxiliaries** are referred to as signalling that a verb is about to follow. Certain verbs are isolated as being auxiliaries in “some of their uses.” Non-conjugational items are singled out as **modals** and the rest as **non-modal operators**.

Insightfully, Systemic Grammar also tries to show an inviting interest in auxiliaries. Relevantly, it is maintained that the auxiliary verb stands first in a discontinuous verbal group [V]. Accordingly, Auxiliary Verbs are *morphologically classified* into two categories: “Non-Modal” and “Modal” and insightfully four criteria are mentioned by which auxiliaries are classified, namely (1) negation (2) inversion (3) substitution and (4) marked positive element.

The paper ends by insightfully ushering us to very important understanding of auxiliaries where eleven auxiliaries are isolated as having twenty eight forms whose occurrence is cleverly realised in four **syntactic structures**, namely ‘*negation*’, ‘*inversion*’, ‘*code*’ and ‘*emphatic affirmation*’. The neutral ‘empty’ auxiliary **do** is suggested to pass all the tests.

* PhD (Professor Emeritus), English Department, Al-Mansour University College, Baghdad, Iraq

In an inviting and subtle sense, the paper also looks at these auxiliaries from the point of view of **Systemic Grammar** as well as of **Transformational Grammar** where the latter cleverly speaks of deep and surface structures.

An insightful conclusion ends this work, synthesising things through bringing together the main thematic strands.

Keywords and Phrases: primary auxiliaries; modal auxiliaries; aspect; volition; probability; obligation; negation; inversion; code; emphatic affirmation

2. Thematic Concerns:

Biber et al recognise (p. 359) the primary auxiliary verbs as being “about twice as common as modal auxiliary verbs.”

Quirk et al divide (pp. 120-124) auxiliary or ‘helping verbs’ into the primary verbs: **be**, **have** and **do** and the modal verbs: **can**, **may**, **will**, **shall**, **could**, **might**, **would**, **should**, and **must**. They suggest that of the three primary verbs, **do** is “only semantically empty.” They also recognise that **Be** contributes to **aspect** and **voice** and **have** to **aspect**. Modal auxiliaries, they argue, contribute to modality in concepts as **volition**, **probability** and **obligation**. They assert that every auxiliary except the **am** form of **Be** has a contracted form and that “contractions ... are institutionalised in both speech and writing.”

Stagberg (p. 175) argues that, omitting **dare** and **need**, there are **ten** modal auxiliaries which precede verb stems and give them special shades of meaning like **futurity**, **volition**, **possibility**, **permission** and **necessity**. He maintains that they are “sometimes called verb **makers** because they signal that a verb is about to follow. “**Must** and **ought** do not have parallel forms... To express the past tense of **must**, in the sense of **necessity**, one says **had to**.” Stagberg recognises (p. 177) that “the periphrastic auxiliary **do** is a special case,” that it is a dummy form – that it provides inversion signalling a question, that it carries the tense, that it provides emphasis, that it replaces a main verb in tag questions and that it expresses an inverted structure in sentences beginning with a negative adverbial like **seldom**, **never**, **not only**:

[example] (p. 178) Never did I dread of such a thing

Christophersen and Sandvel suggest (p. 164) that “the words **dare**, **need** ... differ from most other auxiliaries” in that they generally follow the adverbial as in

She never **dares** to open her mouth.

They seldom **need** to ask for help.

They often **used** to drop in for a chat.

They, however, recognise that **need** is followed by a plain infinitive and that the adverbial follows **need**:

They **need** never ask us to help them.

Earlier (p. 77), Christopherson and Sandvel suggest that “**dare** and **need** are listed as marginal auxiliaries” in that “they are auxiliaries in only some of their uses.”

They isolate BE as an **auxiliary** (pp. 78-79) when followed by the -ing form of a verb in cases like

The man is hitting the boy.

and also, they show, when it is followed by the past participle and when followed by an infinitive with **to** as in

It is broken

We are to meet him tonight

However, they do not regard it as an auxiliary construction in a sentence like the following:

The man is ill/silly.

They recognise (p. 156) that “a group of **catenatives** denoting belief or *opinion* may be used in ... somewhat formal language, while in everyday language, a that-clause, would be preferred... Among these catenative verbs are “**believe, consider, declare, feel, find, imagine, know, prove, suppose, understand**” as in

We **believed** it to have been a mistake

They **declared** this to be a fraud.

Onions suggests (p. 129) that **can**, as an auxiliary, expresses *ability*. Having always independent meaning, “it is used to form *tense* of mood-equivalent. ‘I can’ is suggested to originally mean ‘I know how’ and, hence, ‘I am able to’.

Strang assumes (p. 160) that “the division of function is clear enough for us to label – the non-conjugational items as **modals** and the rest as non-modal operators”

Advocates of **Systemic Grammar** like to talk about “the characters” of the auxiliary verbs and their positions in a verbal group.

He may be going	present modal progressive
He might be going	past modal progressive
He may have been going	present modal perfective progressive
He might have been going	past modal perfective progressive

Muir, also a Systemic Grammarian, characterises (p. 47) **dare** and **need** as being auxiliaries by taking the *enclitic negator* [ie n't] and by *inversion*:

He **dare** n't go. **Dare** we go?

Muir morphologically classifies the Auxiliary Verbs into two categories:

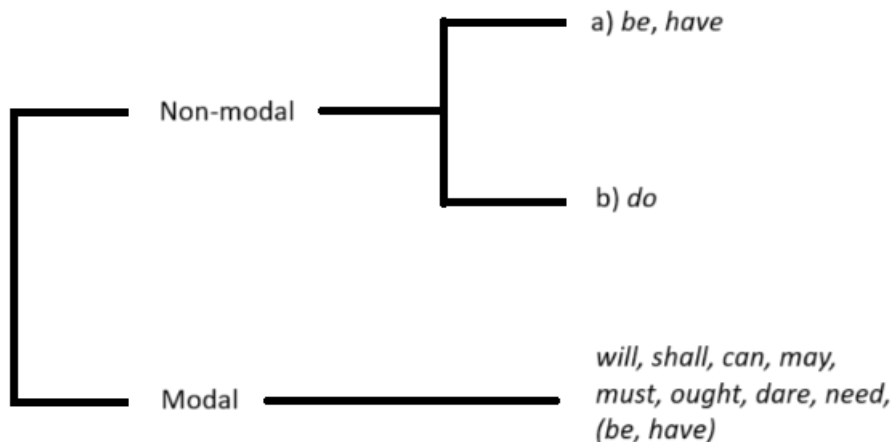

He mentions (pp. 42-43) four main criteria by which auxiliary verbs are classified:

1. **Negation** at which “the auxiliary verbs regularly take the enclitic form of the negator, n’t”:

e.g. I can’t come * I jumpedn’t it

2. **Inversion**. This syntactic function is “characteristic of clauses which are interrogative, and clauses which contain semi-negative adverbs in initial position”:

e.g. **Is** the boy coming? *Rarely had* they seen such things.

3. **Substitution**. Here the function of the auxiliary verb (do) may substitute for a lexical verb:

I like it and so **do** they.

“For this reason, the auxiliary verb (do) is often said to be a “dummy” or “lexically empty” verb.

4. **Marked Positive Element**. Here an auxiliary verb makes it possible to stress, in a verbal group, the *polarity* (the ‘yes-ness’ or the ‘no-ness’) or the **modality** of the verb

He **did** hit the boy.

I **can** come.

Palmer insightfully isolates (pp. 18-19) eleven auxiliaries that have “twenty eight forms”. He suggests that only **be**, **have** and **do** have *-s forms* and that the remainder are **modals**. Palmer realises that what morphologically distinguishes a modal is the absence of an *-s form*.

He recognises that auxiliaries stand apart from the verbs of language in their occurrence in four syntactic structures which he isolates as ‘*negation*’, ‘*inversion*’, ‘*code*’ and ‘*emphatic affirmation*’.

1. **Negation**. Detailing these tests, Palmer suggests (pp. 20-21) that the first test of an auxiliary is whether it is used with *negation* or more precisely whether it has a *negative form*:

I don't like it. (* I like n't it).

Full verbs, as it transpires, cannot occur with the enclitic negative particle **n't**.

* I like **n't** it but I don't like it.

Some verbs ie ‘**catenatives**’ (such as **prefer**, **hate**) may occur with **not** but can be excluded as auxiliaries on the basis that they cannot occur with the contracted form **n't** but they do occur in negative sentences containing an auxiliary verb (do):

I prefer not to ask him but * I prefern't to ask him.

Palmer views the first sentence as positive form, 'not' being associated with the following verbal form.

Other *catenatives* (**want, begin**) can be excluded because they can't pass this test. They occur with **do**.

* I want n't to ask you, but I don't want to ask you.

'May' provides a slight problem. It occurs with **not** but it hasn't a negative form (* may n't). But **mightn't** occurs. **May** is regarded an auxiliary because it satisfies the other tests and has the characteristics of **modals**.

2. **Inversion**. For Palmer, this Test (pp. 22-23) of an auxiliary is whether it can come before the subject in certain types of sentences. The most common type is the 'interrogative':

Is Luria coming? ==> Aux, subject, full verb.

The verbal phrase is shown to be **discontinuous** divided by the subject of the clause, a noun, Luria. The example is a question **but this test is not in terms of a question for a question may be asked by using rising intonation without inversion**. Moreover, **inversion** occurs with **semi negatives** in sentences that are

not questions and with a certain type of **conditional**. **Inversion** also occurs without an auxiliary when an adverbial **of place** comes initially. The following are illustrative examples.

He's coming? /

Seldom **had** I seen such a sight.

Into the room walked John.

Catenatives fails this test:

* Began he to cry

In colloquial speech (go) preceded by (how) is an exception but we have an illustrative form with the same meaning:

How goes it?

How is it going?

3. **Code**. Palmer's third syntactic structure test (pp. 23-24) is 'code' which means "avoidance of repetition of lexical verb." A 'full verb' is "picked up" by an auxiliary. **Code** is often used with "and so" construction:

I can come **and so** can he.

I like it **and so** do they.

The only verbal form that is repeated after “and so” is the **auxiliary**.

Catenatives cannot pass this test:

* I want to ask you and so wants Bill.

Another type of ‘code’ is the form of **question and answer**:

Can I come?

You can.

4. **Emphatic affirmation**. Palmer’s fourth test of auxiliaries (p. 24) is their use in **emphatic affirmation** with the accent upon the auxiliary

You **múst** come.

I **cán** do it.

Palmer makes it clear that the auxiliaries used here (pp. 24-26) are “to emphasise doubtful statements or as a denial of the negative”

I cán come. (=You are wrong to think I cannot).

Other Verbs

- **Do**, Palmer's 'neutral' or 'empty' auxiliary (p. 25) passes all the tests, I don't ... etc except in the imperative where it may occur with (be):

Do be reading when I write.

Do be quiet.

it does not occur with auxiliary.

- **Dare** and **Need**. These verbs pass (Palmer pp. 26-28) the tests of '*negation*' and '*inversion*' and have the characteristics of **modal auxiliaries** (no -s form):

He daren't go.

Need they look?

* Needs he

They may also occur as full verbs in these tests

He does not **dare** to go.

Do they **need** to look?

Thus, the difference between the auxiliary and the full verb is the presence of (**do**) and (to-infinitive) in full verbs and the occurrence with bare-infinitive and the non-inclusion of -s form in the auxiliary. But these are not sufficient criteria to exclude the full verbs from the auxiliaries since the primary auxiliaries have -s form and **ought** is associated with **to-infinitive**. The full verb “**Dare**” may also associate itself with **bare-infinitive** though still there is ‘do’: I **don't dare** ask ...

Now, unless there is **negation** or **inversion**, these auxiliaries do not occur with **code** or **emphatic affirmation**

Did I ask him? No, you daren't.

I needn't come and neither need you.

Semi-negatives together with the **no-series**, *no one* etc help to distinguish the auxiliaries which occur with them from the full verbs **Dare** and **Need**.

The status of **quasi-auxiliary** *used to* is very dubious as an auxiliary. It cannot pass the test of ‘code’ and ‘the tag’

* I used to act like that and so used he. (Code test)

Palmer suggests (p. 28) that he has referred twice to *semi negatives* to characterise the modals. He isolates adverbs like **seldom**, **never**, **scarcely** and **nowhere** as being relevant for **inversion**. He makes it clear that “it is important to refer to these *semi negatives* since they do not function in the **negation test** of the auxiliary in the way **not** does.”

He doesn't go.

* He not goes.

He never goes.

He seldom goes.

Liles who advocates Transformational Grammar analyses (p. 20) a sentence like **She is singing** in the form of a tree as follows:

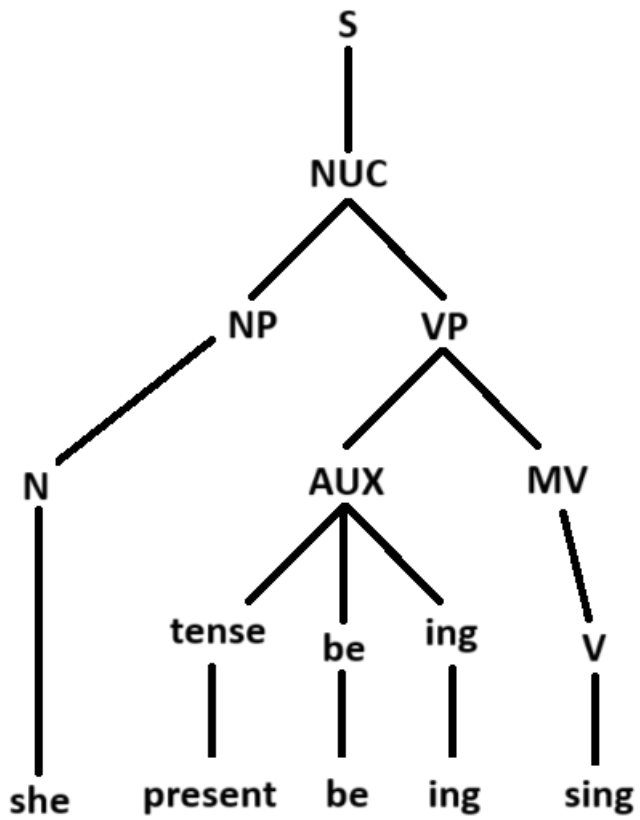

He suggests (p. 21) that “tense is attached to the element that immediately follows it”. He provides a tree (p. 21) “for a structure in which both **have** and **be** have been selected as auxiliaries for the sentence”:

He had been smiling.

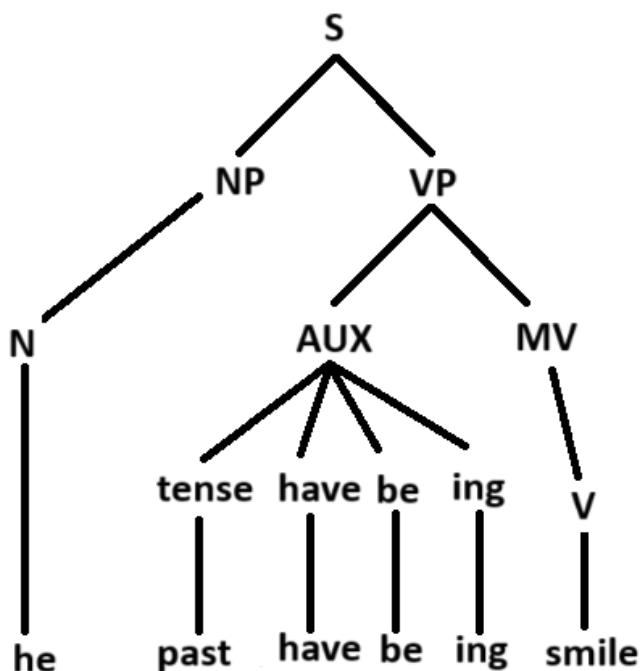

Here is a tree by Liles (p. 23) for the sentence **He could have been running**. It contains the maximum expansion of the auxiliary.

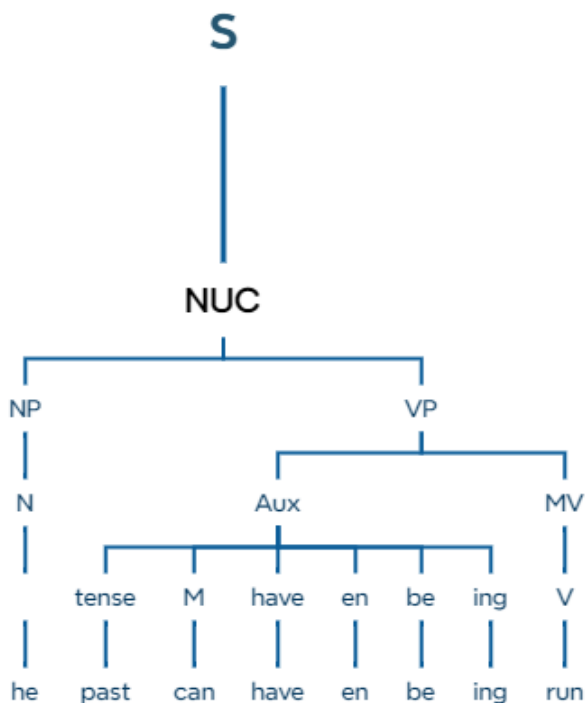

The rearranged structure for the question “Is the boy reading a book?” in Liles (p. 29) is as follows:

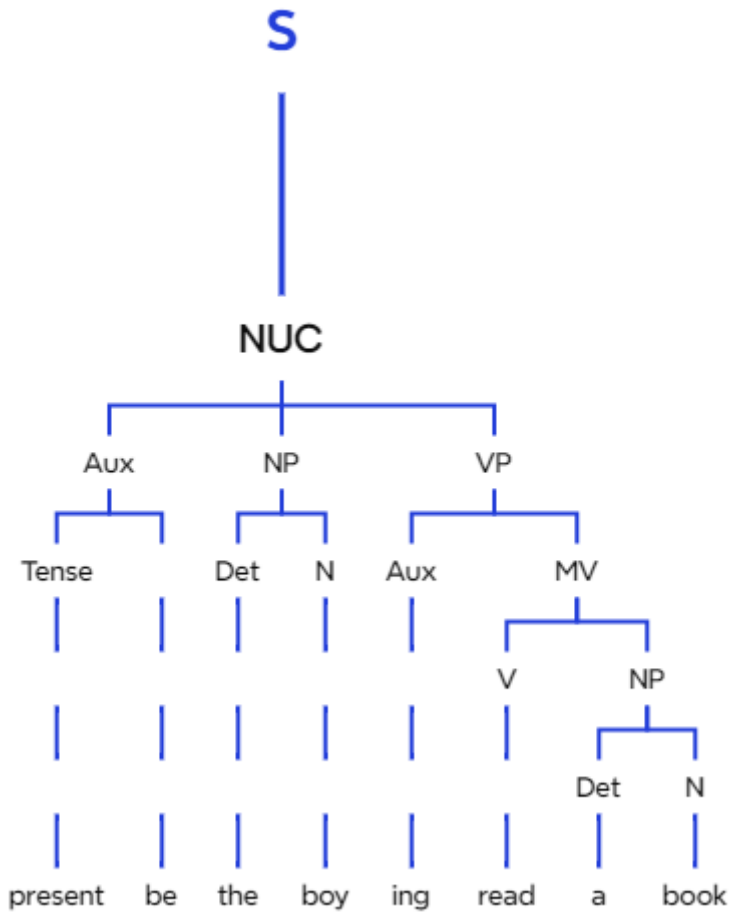

Jacob and Rosenbaum suggest (p. 120) that the deep structure of the sentence

Artemis must leave

“Might be represented in the following way”:

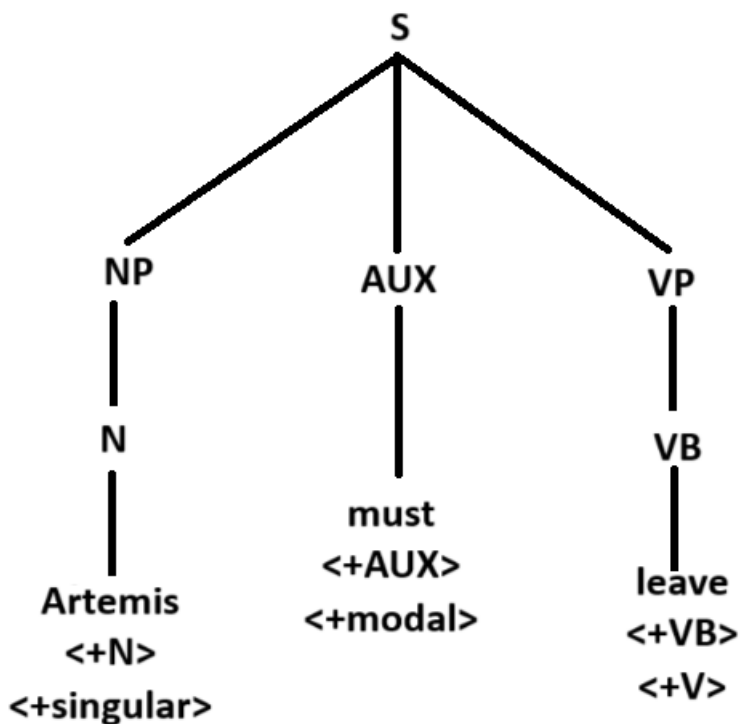

Another illustrative example is given by Jacobs and Rosenbaum (pp. 121-123):

Artemis might leave.

They suggest that the deep structure of the sentence:

Artemis might leave

would be realised as:

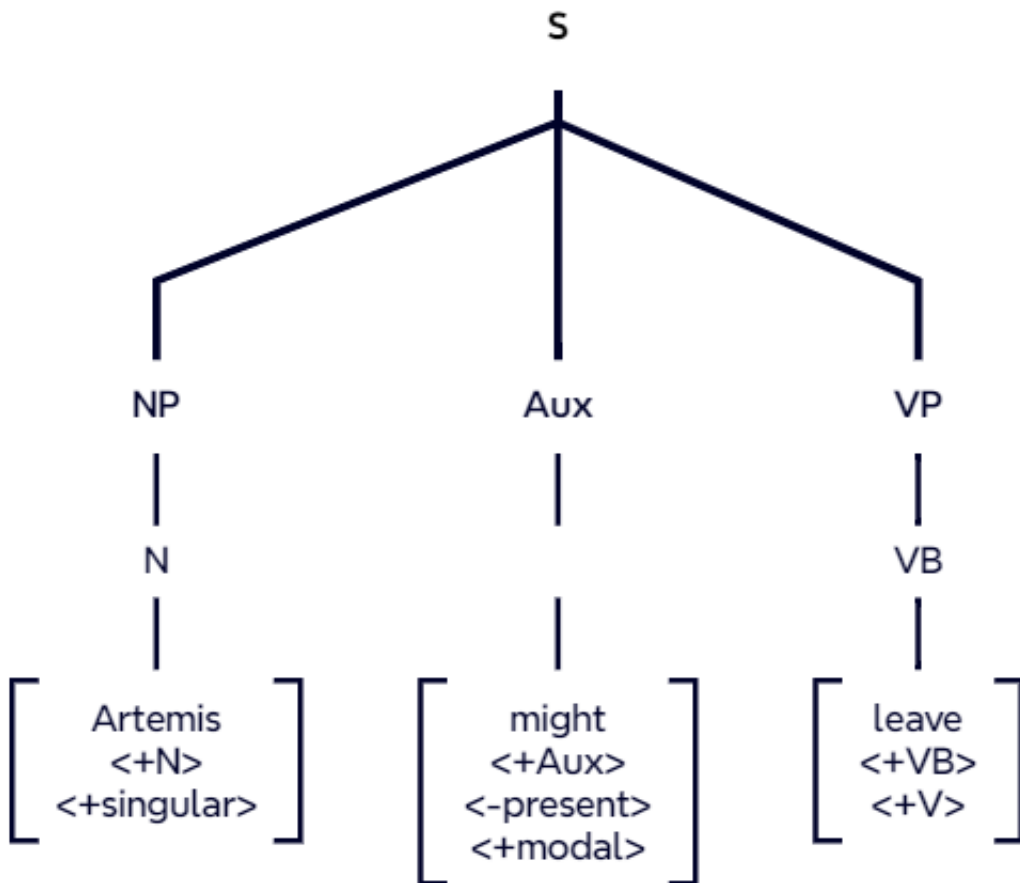

Jacobs and Rosenbaum suggest that “what is permuted to the left of the subject noun phrase is not just a word but an entire auxiliary constituent.”

The deep structure of an interrogative sentence like:

May Artemis leave

is “roughly” illustrated by “the following tree diagram:

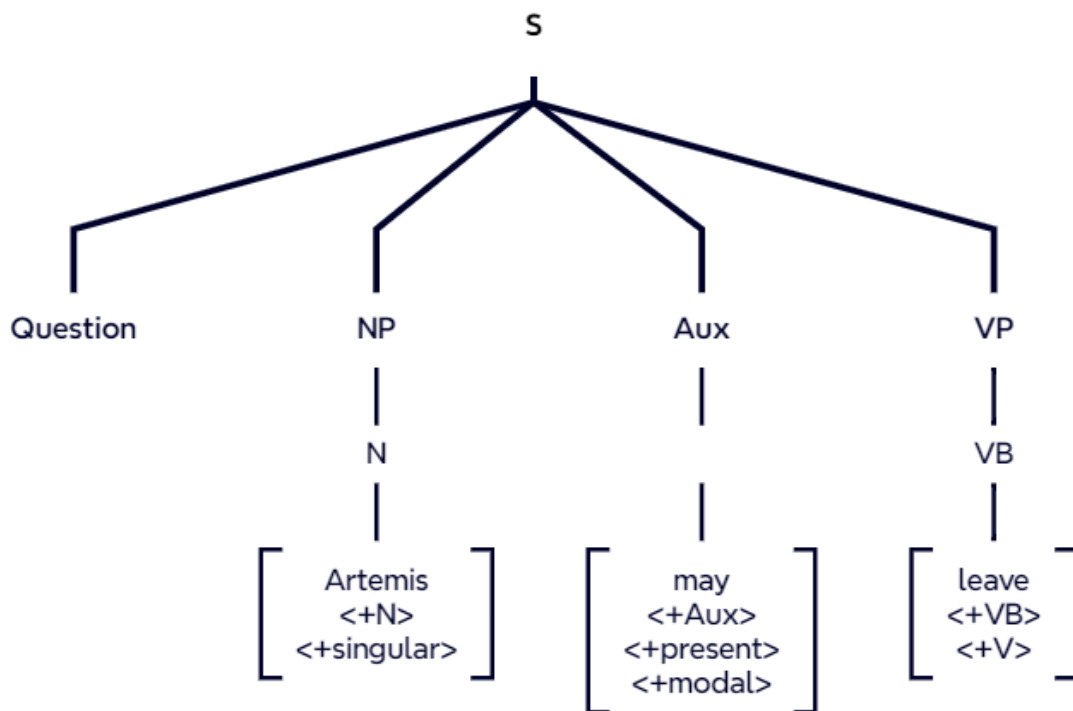

Jacob and Rosenbaum realise that the constituent QUESTION indicates that **surface structure** has to be interpreted as a question. Now the **interrogative transformation** interchanges the auxiliary constituent with the subject noun phrase to produce the following structure:

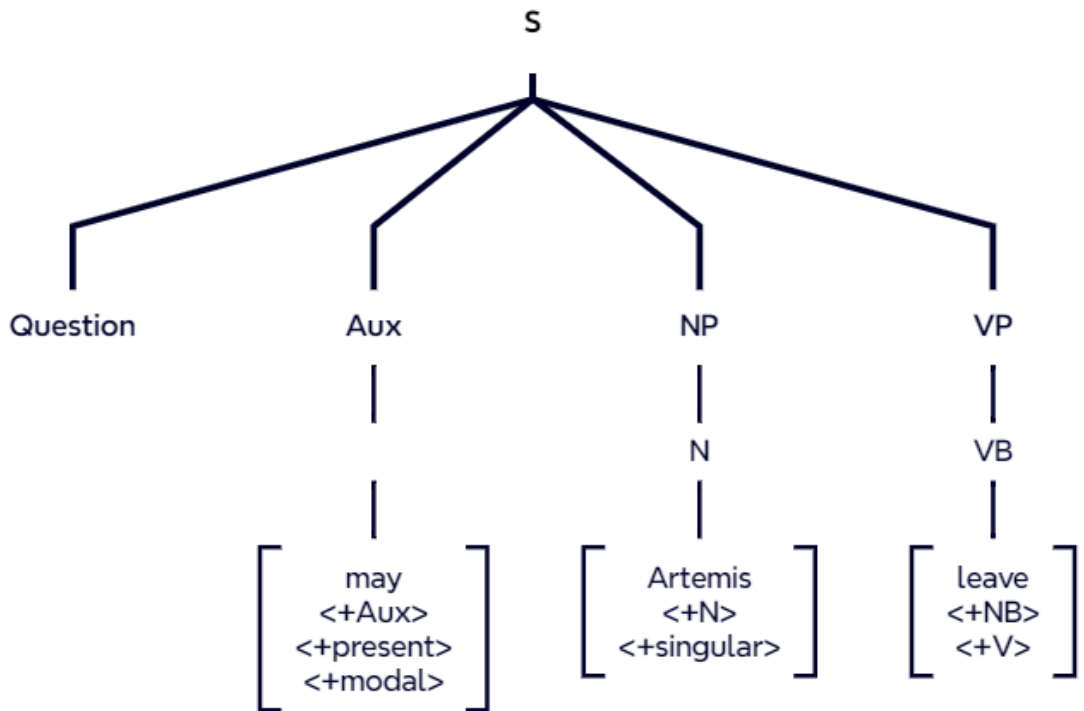

Then the **Question Constituent** is deleted and we will have the following surface structure:

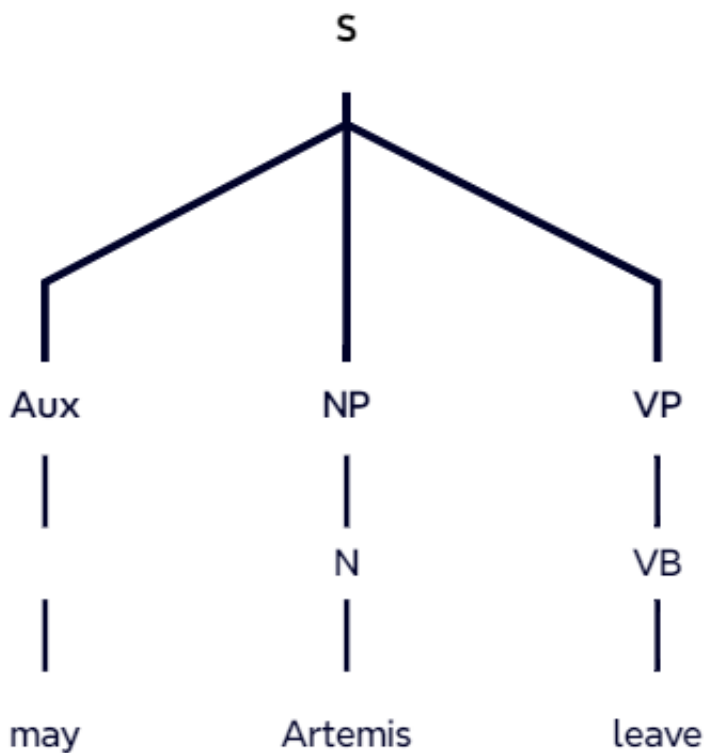

3. Conclusions

To recapture things, the paper has shown that auxiliaries are, grammatically speaking, highly important in specifying the main verbs and **modality**.

In an attempt to deal with the formal characteristics of auxiliaries, the paper isolates **eleven auxiliaries** that have **twenty-eight forms**.

Two kinds of auxiliaries have been isolated, *primary auxiliaries* that contribute to **aspect** and **voice** (with **do** as being semantically empty but useful in the sense of substituting a lexical verb) and *modal auxiliaries* that enact special kinds of meaning in the forms of **obligation**, **volition**, **permission** etc, forms that prove to be useful for a speaker or a writer. **Dare** and **need** are shown to be marginal auxiliaries in that they take **n't**, an enclitic negator, and also through **inversion**.

It has also been shown that what isolates auxiliary verbs from the verbs of the language is the occurrence of these verbs in certain syntactic structures that are realised in Palmer as 'negation', 'inversion', 'code' and 'emphatic structures'. **Catenatives** such as **prefer** and **need** are excluded as auxiliaries in that they cannot occur with the enclitic negator **n't**. These verbs also fail the syntactic structure of **inversion** (* Began he to read). They are also shown to fail the syntactic structure of **code** (* She wants to play and so wants the boy).

The paper has also shown both primary and modal auxiliaries as being quite useful in the sense that the former, except **do**, contribute to **aspect** and **voice** and the latter, to special shades of meaning in the form of **obligation**, **volition**, **permission** etc. As marginal auxiliaries, **dare** and **need** are shown to be marginal auxiliaries through **inversion** and through taking **n't**, an enclitic negator.

In a significant sense, it has been realised that what isolates auxiliary verbs from the verbs of the language is their occurrence in certain syntactic structures.

4. References

- [1] Biber, Douglas, Stig Johansson, Geoffrey Leech, Susan Conrad and Edward Finegan (1999). **Longman Grammar of Spoken and Written English**. Pearson Education Limited, Essex, England.
- [2] Christophersen, P and A.O. Sandved (Reprinter 1972) Macmillan Education Limited. London
- [3] Muir, James (1972) **A Modern Approach to English Grammar: An Introduction to systemic Grammar**. B.T. Batsford Ltd. London.
- [4] Onions, C.T. (1971) **Modern English Syntax**. Route Ledge and Kegan Paul, London.
- [5] Palmer, F. R. (1974) **The English Verb**. Longman Limited. London.
- [6] Quirk, Randolph, Sidney Greenbaum, Geoffrey Leech and Jan Svartvik (1985). **A Comprehensive Grammar of the English Language**. Longman Group UK Limited.
- [7] Scott, F.S., C.C. Bowley, C.S. Brockett, J.G. Brown and P.R. Goddard (Reprinted, 1973) **English Grammar: A Linguistic Study of its Classes and Structures**. Heinmann Educational Books. London.
- [8] Stageberg, Norman C. (1980) **An Introductory English Grammar**. Holt Rinehart Winston. Fourth Edition.
- [9] Strang, Barbara M.H. (1969) **Modern English Structure**. Edward Arnold (Publishers) Ltd, London.

المزايا الشكلية للأفعال المساعدة

أ. د. متمرس. عزيز يوسف المطلي¹
Aziz.yousif@muc.edu.iq

الخلاصة:

يحاول البحث أن يحدد الخواص الشكلية للأفعال المساعدة وهو يقدم نحويين يحاولون أن يتحدثوا عن هذه القضية النحوية المهمة. كما يحاول البحث أيضاً، على نحو ممتع، أن يُظهر كيف تشتغل هذه الأفعال المساعدة في الجمل وأن يقسمها على نحو مدرك، إلى أفعال أولية مساعدة وإلى أفعال مساعدة لها هيئة واحدة. كما يُظهر البحث أن الأفعال الأخيرة تسهم في إظهار معاني المشيئة والإلزام. وعلى نحو متبصر، يحاول القواعد النظامي أن يُظهر اهتماماً مثيراً بالأفعال المساعدة وبكل ما يتصل بذلك. وفي ما يخص حدوث هذه الأفعال المساعدة يُشير البحث إلى أنها تأتي أولاً في المجموعة الفعلية غير المستمرة وطبقاً لذلك يمكن تصنيف الأفعال المساعدة على نحو مبهر، إلى أربعة أقسام تتحدث عن (1) النفي (2) القلب (3) التعويض (4) العنصر الإيجابي.

ينتهي البحث، على نحو دقيق، مرشداً لفهم مهم للأفعال المساعدة، إذ يمكن أفراد أحد عشر فعلاً لها ثمان وعشرون هيئة يدرك حدوثها، على نحو ذكي، في أربعة بنى نحوية وهي "النفي"، "القلب"، "الشفرة"، و"الأثبات المؤكد"، محاولاً توليف الأشياء بوساطة توحيد الكلمات والمصطلحات الرئيسة وإظهار قسمين لهذه الأفعال وهي الأفعال المساعدة الأولى. أما الفعل المساعد الفارغ (DO) فنرى أنه يجتاز كل الإختبارات. وفي معنى جذاب ودقيق ينظر البحث أيضاً إلى هذه الأفعال المساعدة من وجهة نظر النحو النظامي وكذلك النحو الذي يتحدث بذلك عن البنى السطحية والعميقة ألا وهو النحو التوليدي.

الكلمات والعبارات المفتاحية:

الأفعال المساعدة الأولى، الأفعال المساعدة الثانية، الصفة، الألتزام، النفي، القلب، الشفرة، الأثبات المؤكد.

¹ أستاذ دكتور متمرس في كلية المنصور الجامعة قسم اللغة الانكليزية – العراق - بغداد